

SMD Power Inductors

STD0804 Series

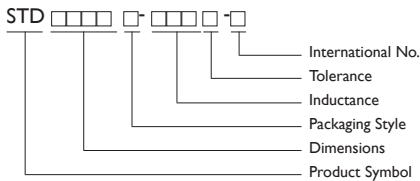

PRODUCT IDENTIFICATION



- Packaging: T: Tape and Reel
- Tolerance: M=±20%
- Note: YAGEO will start to release STD Series inductors with lead-free terminals which meet SONY SS-00259's criteria for lead-free product in Q2 of 2004, and YAGEO Internal No will be changed to "N" as identification. Ex. STD0804T-100M-B-N

SHAPES AND DIMENSIONS

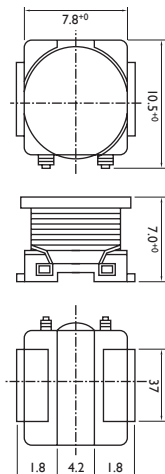

Yageo SMD power inductors are best designed for noise / EMI / RFI filters for surface mounting applications.

These components contain tremendous electrode straight, solder heat resistance and outstanding solderability. These products are specially designed for flow, reflow and wave soldering required for surface mounting applications.

APPLICATIONS

Power supply, power amplifiers
Switching regulators.

FEATURES

For high current applications.
Specially designed for high density surface applications.
Ideal for solder flow, reflow and wave soldering applications.

ELECTRICAL CHARACTERISTICS

PART NO.	INDUCTANCE * ($\mu\text{H} \pm 10\%$)	DC RESISTANCE (Ω^{+0})	RATED CURRENT (mA)
STD0804T-560K-S	56	0.25	900
STD0804T-680K-S	68	0.30	800
STD0804T-820K-S	82	0.37	700
STD0804T-101K-S	100	0.38	600
STD0804T-121K-S	120	0.58	550
STD0804T-151K-S	150	0.72	500
STD0804T-181K-S	180	0.80	450
STD0804T-221K-S	220	0.83	400
STD0804T-271K-S	270	1.10	350
STD0804T-331K-S	330	1.15	300

* Tested at HP4263A 1KHz, 1 Volt.

** Inductance Drop = 10% Typ. at Rated Isat.

Operating Temperature Range -40°C to +85°C



RECOMMEND SOLDERING CONDITIONS

for: CL/ CLH/ SQV/ SMD power inductors/ SMD Chip Beads/ SMD Filters, Transformers, Current Sensors

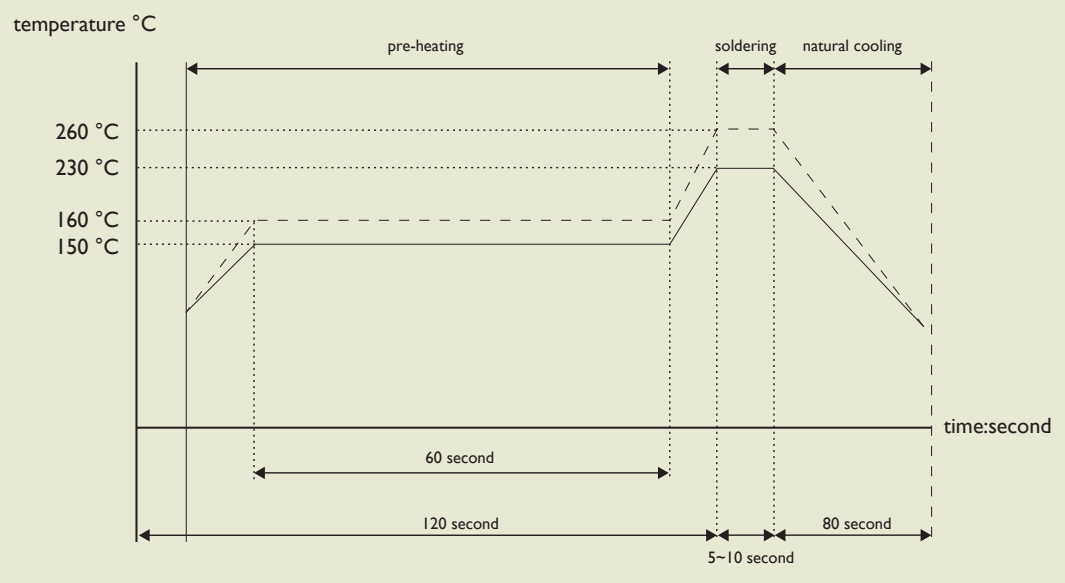

for: lead solder	—————
for: lead-free solder

SMD Power Inductors

STD 1109 Series



FEATURES

Power supply, power amplifiers
Switching regulators.

PRODUCT IDENTIFICATION

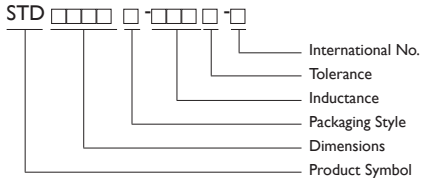

- Packaging: T: Tape and Reel
- Tolerance: M=±20%
- Note: YAGEO will start to release STD Series inductors with lead-free terminals which meet SONY SS-00259's criteria for lead-free product in Q2 of 2004, and YAGEO Internal No will be changed to "N" as identification. Ex. STD1109T-100M-B-N

SHAPES AND DIMENSIONS

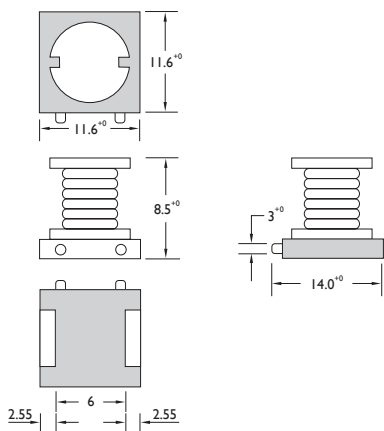

Yageo SMD power inductors are best designed for noise / EMI / RFI filters for surface mounting applications.

These components contain tremendous electrode straight, solder heat resistance and outstanding solderability. These products are specially designed for flow, reflow and wave soldering required for surface mounting applications.

APPLICATIONS

For high current applications.

Specially designed for high density surface applications.

Ideal for solder flow, reflow and wave soldering applications.

ELECTRICAL CHARACTERISTICS

PART NO.	INDUCTANCE ($\mu\text{H} \pm 20\%$)*	DC RESISTANCE (Ω)	RATED CURRENT (A) Max.
STD1109T-100M-B-S	10	0.06	3.50
STD1109T-120M-B-S	12	0.07	3.40
STD1109T-150M-B-S	15	0.08	3.10
STD1109T-180M-B-S	18	0.09	3.00
STD1109T-220M-B-S	22	0.10	2.60
STD1109T-270M-B-S	27	0.11	2.40
STD1109T-330M-B-S	33	0.12	2.30
STD1109T-390M-B-S	39	0.14	2.10
STD1109T-470M-B-S	47	0.17	1.95
STD1109T-560M-B-S	56	0.19	1.85
STD1109T-680M-B-S	68	0.22	1.65
STD1109T-820M-B-S	82	0.25	1.50
STD1109T-101M-B-S	100	0.35	1.40
STD1109T-121M-B-S	120	0.40	1.30
STD1109T-151M-B-S	150	0.47	1.20
STD1109T-181M-B-S	180	0.63	1.00
STD1109T-221M-B-S	220	0.73	0.95
STD1109T-271M-B-S	270	0.97	0.90
STD1109T-331M-B-S	330	1.15	0.80
STD1109T-391M-B-S	390	1.30	0.75
STD1109T-471M-B-S	470	1.48	0.65
STD1109T-561M-B-S	560	1.90	0.60
STD1109T-681M-B-S	680	2.45	0.50
STD1109T-821M-B-S	820	2.55	0.48
STD1109T-102M-B-S	1000	3.00	0.46
STD1109T-122M-B-S	1200	3.50	0.35

Test Instruments : HP4261 RF Impedance for L, IDC

Digital Multimeter SC-7401 for RDC

*Test at HP4263A 1KHz, 1Volt



ELECTRICAL CHARACTERISTICS : LEAD-FREE & ROHS COMPLIANCE

PART NO.	INDUCTANCE (nH±20%)	TEST FREQ (MHZ)	R _{dc} (Ω)Max	IDC (A)Max.
STD1109T-100 □ -B-N	10	1KHz, 1V	0.06	3.5
STD1109T-120 □ -B-N	12	1KHz, 1V	0.07	3.4
STD1109T-150 □ -B-N	15	1KHz, 1V	0.08	3.1
STD1109T-180 □ -B-N	18	1KHz, 1V	0.09	3
STD1109T-220 □ -B-N	22	1KHz, 1V	0.1	2.6
STD1109T-270 □ -B-N	27	1KHz, 1V	0.11	2.4
STD1109T-330 □ -B-N	33	1KHz, 1V	0.12	2.3
STD1109T-390 □ -B-N	39	1KHz, 1V	0.14	2.1
STD1109T-470 □ -B-N	47	1KHz, 1V	0.17	1.95
STD1109T-560 □ -B-N	56	1KHz, 1V	0.19	1.85
STD1109T-590 □ -B-N	68	1KHz, 1V	0.22	1.65
STD1109T-820 □ -B-N	82	1KHz, 1V	0.25	1.5
STD1109T-101 □ -B-N	100	1KHz, 1V	0.35	1.4
STD1109T-121 □ -B-N	120	1KHz, 1V	0.4	1.3
STD1109T-151 □ -B-N	150	1KHz, 1V	0.47	1.2
STD1109T-181 □ -B-N	180	1KHz, 1V	0.63	1
STD1109T-221 □ -B-N	220	1KHz, 1V	0.73	0.95
STD1109T-271 □ -B-N	270	1KHz, 1V	0.97	0.9
STD1109T-331 □ -B-N	330	1KHz, 1V	1.15	0.8
STD1109T-391 □ -B-N	390	1KHz, 1V	1.3	0.75
STD1109T-471 □ -B-N	470	1KHz, 1V	1.48	0.65
STD1109T-561 □ -B-N	560	1KHz, 1V	1.9	0.6
STD1109T-681 □ -B-N	680	1KHz, 1V	2.45	0.5
STD1109T-821 □ -B-N	820	1KHz, 1V	2.55	0.48
STD1109T-102 □ -B-N	1000	1KHz, 1V	3	0.46
STD1109T-122 □ -B-N	1200	1KHz, 1V	3.5	0.35

NOTE : □ -tolerance M=±20% / T=±30%

1.Operating temperature range -40°C~85°C

3.Inductance drop =10% typ.

"-N"FOR COMPLETELY LEAD FREETYPE(INCLUDING FERRITE BODY & SOLDER)



TAPE DIMENSIONS

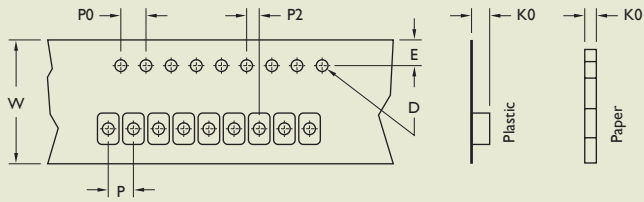

TAPE MATERIAL

Carrier Tape : Polystyrene

Cover Type : Polyethylene

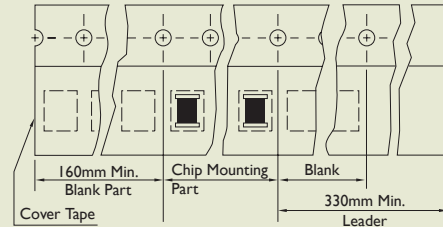

REEL DIMENSIONS

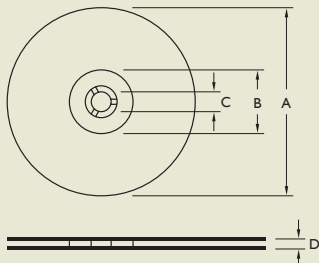

RECOMMENDED PATTERN

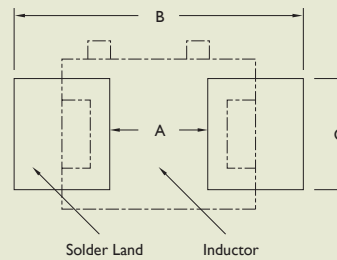

TYPE	TAPE DIMENSIONS							RECOMMENDED PATTERN				REEL DIMENSIONS				QUANTITY /REEL
	K0	D	E	W	P	P0	P2	A	B	C	A	B	C	D		
	Dimensions : mm															
STD0804	5.4	1.55	1.75	24	16	4	2	4.0	9	4.5	330	100	13	24.4	750	
STD1109	8.7	1.55	1.75	24	20	4	2	6	12~14	5	330	100	13	24.4	400	

TYPICAL INDUCTANCE ENERGY STORAGE VS. CURRENT

Test instruments : HP4191A RF Impedance Analyzer

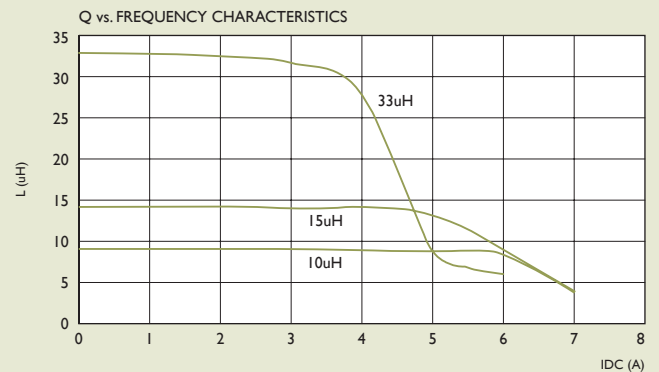
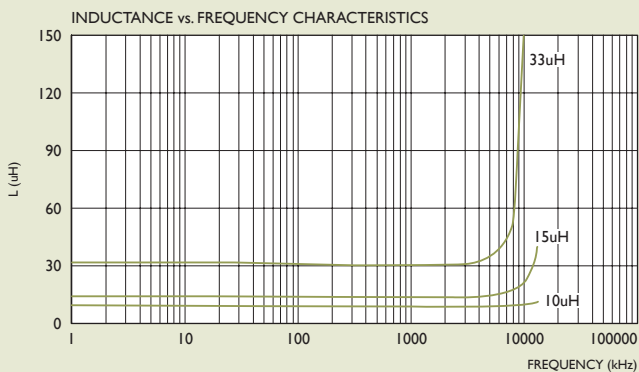



STD SERIES RELIABILITY TEST

I-1 MECHANICAL PERFORMANCE

NO.	ITEM	SPECIFICATION	TEST CONDITIONS
I-1-1	Vibration	Appearance : No Damage L Change : within $\pm 10\%$ Q Change : within $\pm 30\%$ RDC : within Specification	Test device shall be soldered on the substrate. Oscillation Frequency : 10 to 55 to 10Hz for 1Min. Amplitude : 1.5mm Time : 2Hrs. for each Axis (X,Y & Z), Total 6Hrs.
I-1-2	Resistance to Soldering Heat	Appearance : No Damage	Pre-heating : 150°C, 1Min. Solder Composition : Sn/Pb = 63/37 Solder Temperature : 260 \pm 5°C Immersion Time : 10 \pm 1Sec.
I-1-3	Solderability	The electrodes shall be at least 90% covered with new solder coating.	Pre-heating : 150°C, 1Min. Solder Composition : Sn/Pb = 63/37 Solder Temperature : 230 \pm 5°C Immersion Time : 4 \pm 1Sec.

I-2 ENVIRONMENTAL PERFORMANCE

NO.	ITEM	SPECIFICATION	TEST CONDITIONS															
I-2-1	Temperature Shock	Appearance : No Damage L Change : within $\pm 10\%$ L Change : within $\pm 30\%$ RDC : within Specification	10 Cycles (Air to Air) Cycles shall Consist of : 30Min. Exposure to -55°C 30Min. Exposure to 125°C 15Sec. Max. Transition between Temperatures Measured after Exposure in the Room Condition for 24Hrs.															
I-2-2	Temperature Cycle		One Cycle <table border="1" style="margin-left: 20px;"> <thead> <tr> <th>Step</th> <th>Temperature (°C)</th> <th>Time (Min.)</th> </tr> </thead> <tbody> <tr> <td>1</td> <td>-25 \pm 3</td> <td>30</td> </tr> <tr> <td>2</td> <td>25 \pm 2</td> <td>3</td> </tr> <tr> <td>3</td> <td>85 \pm 3</td> <td>30</td> </tr> <tr> <td>4</td> <td>25 \pm 2</td> <td>3</td> </tr> </tbody> </table> Total : 100 Cycles Measured after Exposure in the Room Condition for 24Hrs.	Step	Temperature (°C)	Time (Min.)	1	-25 \pm 3	30	2	25 \pm 2	3	3	85 \pm 3	30	4	25 \pm 2	3
Step	Temperature (°C)	Time (Min.)																
1	-25 \pm 3	30																
2	25 \pm 2	3																
3	85 \pm 3	30																
4	25 \pm 2	3																
I-2-3	Humidity Resistance		Temperature : 40 \pm 2°C Relative Humidity : 90 ~ 95% Time : 1000Hrs. Measured after Exposure in the Room Condition for 24Hrs.															
I-2-4	High Temperature Resistance		Temperature : 85 \pm 3°C Relative Humidity : 20% Applied Current : Rated Current Time : 1000Hrs. Measured after Exposure in the Room Condition for 24Hrs.															
I-2-5	Low Temperature Resistance		Temperature : -25 \pm 3°C Relative Humidity : 0% Time : 1000Hrs. Measured after Exposure in the Room Condition for 24Hrs.															



RECOMMEND SOLDERING CONDITIONS

for: CL/ CLH/ SQV/ SMD power inductors/ SMD Chip Beads/ SMD Filters, Transformers, Current Sensors

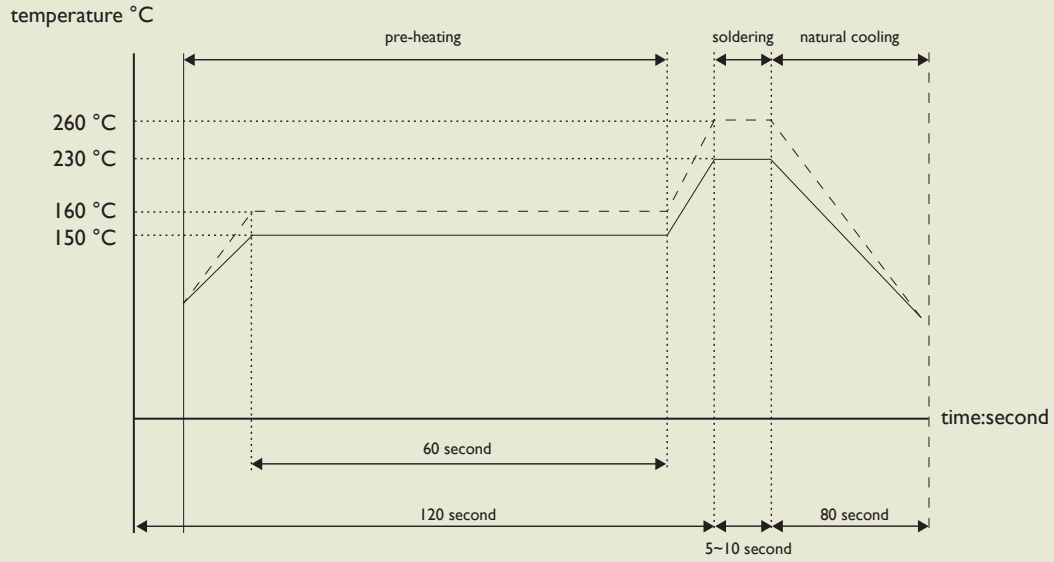

for: lead solder	—————
for: lead-free solder